

METALMASTER

SWINGBEAM GUILLOTINE OPERATION MANUAL



Models.

**HG-2504, HG-2506, HG-3206
HG-3212, HG-4006, HG-4012**

Edition No : SB001

Date of Issue : 5/07/2016

www.machineryhouse.com.au



OPERATION MANUAL

MACHINE DETAILS

MACHINE	HYDRAULIC GUILLOTINE
MODEL NO.	
SERIAL NO.	
DATE OF MANF.	

Distributed by



www.machineryhouse.com.au

www.machineryhouse.co.nz

Note:

This manual is only for your reference. Owing to the continuous improvement of the machine, changes may be made at any time without obligation or notice. Please ensure the local voltage is the same as listed on the specification plate before operating this electric machine.



NOTE:

In order to see the type and model of the machine, please see the specification plate. Usually found on the back of the machine. See example (Fig.1)

METALMASTER	
PRODUCT SPECIFICATION	
MODEL:	<input type="text"/>
CAPACITY:	<input type="text"/>
SER. NO:	<input type="text"/>
MFG DATE:	<input type="text"/>
WEIGHT:	<input type="text"/>
VOLTS:	<input type="text"/>
MOTOR Kw:	<input type="text"/>
www.machineryhouse.com.au	
Made in China	

Fig.1



OPERATION MANUAL

CONTENTS:

1. GENERAL MACHINE INFORMATION

1.1 Specifications.....	4
1.2 Standard Equipment.....	4
1.3 Overall Drawings.....	5

2. IMPORTANT INFORMATION

2.1 Safety Requirements.....	6
2.2 Safety Features of the Machine.....	8
2.3 Lifting Instructions.....	10

3. INSTALLATION

3.1 Base Foundation and Securing Points.....	11
3.2 Machine Leveling.....	12
3.3 Checking the Power Supply.....	12
3.4 Attaching the Accessories.....	13
3.5 Fill the Hydraulic Oil Tank.....	14

4. COMMISSIONING

4.1 Preparation of the Machine.....	15
4.2 Omrom E3Z Safety Sensor Alignment.....	16
4.3 Calibrate "X" Axis on Controller.....	18
4.4 Commissioning Check List.....	18

5. OPERATION INSTRUCTION

5.1 Pre-Operational Safety Check Prior to Operating.	19
5.2 NC89 Controller Operation.....	20
5.3 Setting the Blade Gap.....	21

6. MAINTENANCE

6.1 Type and frequency of Inspections.....	22
6.2 Lubrication Points.....	23
6.3 Changing Oil.....	24
6.4 Changing The Filter.....	25
6.5 Adjusting Blade Clearance & Parallelism.....	26
6.6 Troubleshooting.....	27

APPENDIX

A. Hydraulic Circuit Diagram.....	28
B. Electrical Circuit Diagram.....	30
General Machinery Safety Instructions.....	34



OPERATION MANUAL

1.1 SPECIFICATIONS:

Machine Type	HG-2504	HG-2506	HG-3206	HG-3212	HG-4006	HG-4012
Shearing Length (mm)	2500	2500	3200	3200	4000	4000
Material Capacity Mild Steel (mm)	4	6	6	12	6	12
Material Capacity Stainless Steel (mm)	2.5	4	4	8	4	8
Shear Angle (degree)	1.5	1.5	1.5	1.5	1.5	1.5
Back Gauge Range (mm)	900	1000	1000	1000	1000	1000
System Pressure	18	18	18	18	18	18
Oil Tank Volume	150	170	205	300	205	420
Dimensions						
Width (mm)	3130	3130	3840	3925	4630	4735
Depth (mm)	1530	1530	1675	1800	1800	2000
Height (mm)	1600	1600	1620	1940	1700	2040
Height of Work Table (mm)	740	800	800	800	800	860
Weight (kgs)	4000	5280	7100	11000	8860	13500
Main Motor 3 Phase 415 V 50Hz (kW)	4	7.5	7.5	18.5	7.5	18.5
Back Gauge 3 Phase 415 V 50 Hz (kW)	0.55	0.55	0.55	0.55	0.55	0.55

1.2. STANDARD EQUIPMENT:

- Back-gauge assembly
- Front guarding
- Foot switch and control panel
- Front sheet supports
- Toolset and Instruction manual

OPTIONAL EQUIPMENT

- Rear pneumatic sheet supports.



OPERATION MANUAL

1.3. OVERALL DRAWINGS

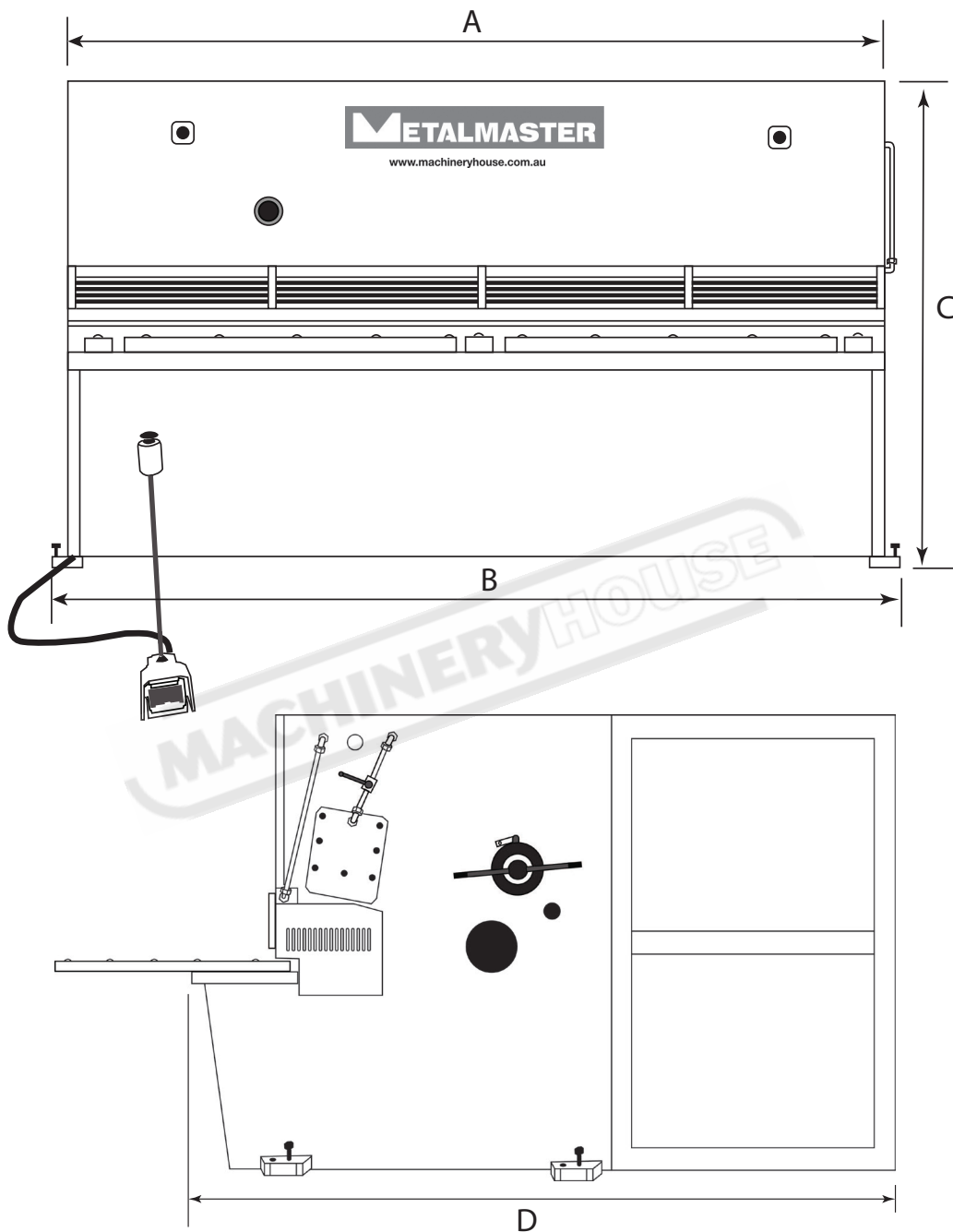

mm	HG-2504	HG-2506	HG-3206	HG-3212	HG-4005	HG-4012
A	3130	3130	3840	3925	4630	4735
B	3230	3230	3990	4175	4830	4935
C	1600	1600	1620	1940	1700	2040
D	2530	2530	2675	2800	2800	3000



OPERATION MANUAL

2.1 SAFETY REQUIREMENTS

DO NOT use this machine unless a qualified person has instructed you in the safe use and operation of the machine.

The most common metal guillotine injuries are crushed or amputated fingers.

Most of these accidents are not caused by the blade of the guillotine, but by the clamps that hold the sheet metal being cut. Other injuries are from fingers jamming under the sheet that is to be cut, and strain injuries while handling large and awkward sheets of metal.

By law, guillotines must be guarded, and operators must be trained. Safe working procedures must be in place to prevent injuries.



Safety glasses must be worn at all times in work areas. Earmuffs should be worn if the work area is noisy.



Sturdy footwear must be worn at all times in work areas.



Gloves should be worn when handling the material used on this machine.



Long and loose hair must be contained with a net or under a hat

The following guidelines can be used to identify workplace hazards and to reduce the risks when using metal guillotines.

It is an unsafe practice for two people to work at a guillotine unless both operators are provided with interlocked actuating devices (usually a foot control). However in some guillotine operations, for example cutting large sheets, two operators may be required to maneuver the sheets into position before cutting. For such operations safe work procedures should be developed to control any hazards.





OPERATION MANUAL

SAFETY CHECKS BEFORE OPERATING

- Ensure fixed guards are in place to prevent hands or other parts of the body from entering areas of high risk
- Guards or safety devices must never be removed or adjusted, except by an authorized person for maintenance purposes.
- Working parts should be well lubricated and free of rust and dirt.
- The area around the machine must be adequately lit and kept free of materials, which might cause slips or trips.
- Be aware of other personnel in the immediate vicinity and ensure the area is clear before using equipment.
- Familiarize yourself with and check all machine operations and controls.
- Ensure cutting table is clear of scrap and tools.
- Faulty equipment must not be used. Immediately report suspect machinery

SAFETY CHECKS WHEN OPERATING

- Do not attempt to cut material beyond the capacity of the machine.
- Never attempt to cut rod, strap or wire with this machine.
- Use correct lifting procedures when handling large sheets of material.
- Take extreme care during the initial feeding of the workpiece into the machine.
- The workpiece should always be held sufficiently far back from the edge being fed into the guillotine.
- Ensure fingers and limbs are clear before operating the guillotine.
- Hold material firmly to prevent inaccurate cutting due to creep.
- When cutting ensure feet are positioned to avoid contact with the foot operated lever.

SAFETY CHECKS AFTER OPERATION

- Remove all off cuts and place them in either the storage rack or waste bin.
- Leave the work area in a safe, clean and tidy state.

POTENTIAL HAZARDS

- Cuts from the sharp edges and burrs on the sheets before and after cutting
- Parts of the body being caught in crush and pinch points.
- Injuries caused when handling metal sheets



OPERATION MANUAL

2.2. SAFETY FEATURES OF THE MACHINE:

The electrical and hydraulic circuits of your machine are designed to allow operation with maximum safety. The following precautions are available on the machine for enhanced safety.

There are four Emergency stop buttons (engaging type) on the machine. Two are found on the front of the machine, one on the foot switch control unit, and one on the main control unit. Once the button has been pressed to reset the emergency stop, the red button must be rotated to reset the stop.

Foot pedal control

Emergency stop button (engaging type) is available on the foot switch control unit. The foot pedal when pressed activates the shearing beam and must be held in the depressed position until the machine has completed its cut. Releasing the foot pedal during the shearing operation will return the machine to the top of its stroke when controller is set to single cut.

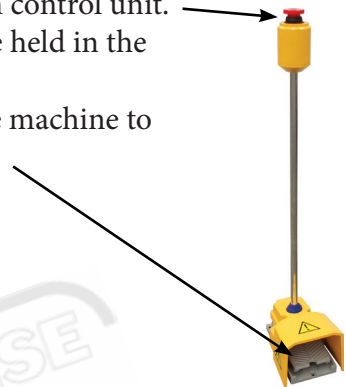

Main Controls

The main machine operating controls are located on the pendant.



1	Continuous or Single Cut	5	Power On Indicator Light
2	Rear Guard Sensor Light	6	Illuminated Pump Start Button
3	Shadow Line Light ON/OFF	7	Hydraulic Pump Stop
4	Power ON/OFF to Controller	8	Emergency Stop

METALMASTER

OPERATION MANUAL

To prevent the operator or other persons from accidental injury the machine operation includes a photoelectric light guard at the back of the machine



3 x Photoelectric safety cells are placed on both sides of the back of the machine. When the beam is broken the machine stops.



Once the beam has been broken the system needs to be reset. This is done by pressing the reset button on the electrical cabinet.



OPERATION MANUAL

2.3 LIFTING INSTRUCTIONS

On the day that the machine arrives, make sure that a crane with sufficient capacity is available to unload the machine from the vehicle. Make sure access to the chosen site is clear and that doors and ceilings are sufficiently high and wide enough to receive the machine.

To handle the Guillotine, use only the two sling lifting points located on the top of the end plates. (Fig. 2.3) The slings should be positioned so the machine is level when lifted.

When using slings please take note of the sling angle and the loads that apply

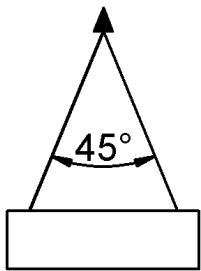

Fig 2.1.

When the slings are at a 45° angle then each sling will carry the equivalent of 50% of load weight. (Fig.2.1).

When the slings are at a 90° angle then each sling will carry the equivalent of 75% of the load weight on each sling. (Fig 2.2)

Note! Metalmaster recommend not to exceed 90° angle

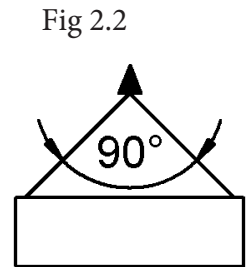

Fig 2.2

Lifting Points

When lifting the machine only use the lifting points on the machine. (Fig. 2.3) and sling as per diagram below. (Fig. 2.4) Ensure that when lifting, the machine does not tip over.

Check that the lifting slings do not interfere with the hydraulic pipes or electrical conduits. Certified lifting slings only should be used.

Failure to follow these instructions could cause damage to the machine

Fig. 2.3
Lifting Point

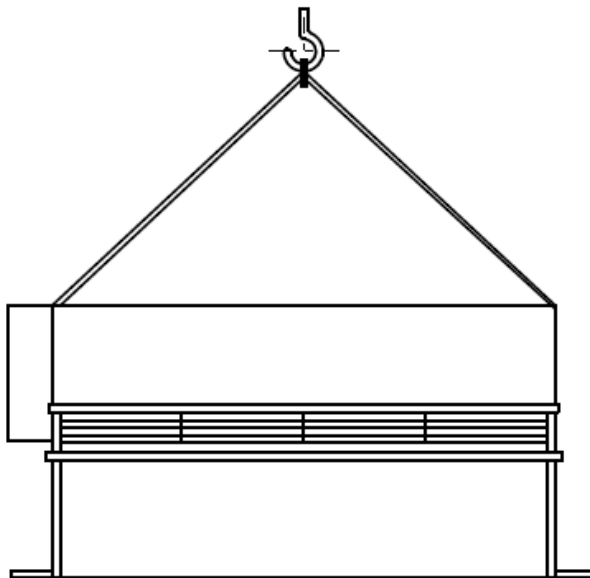
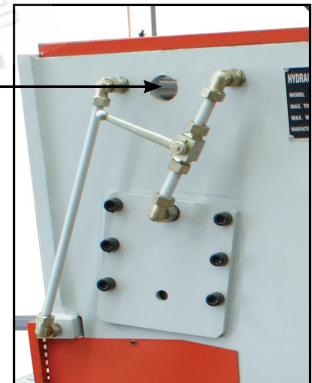
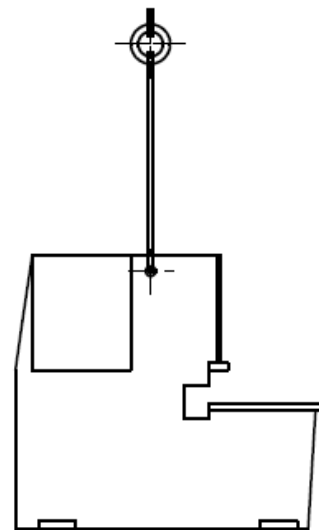

Fig. 2.4





OPERATION MANUAL

3. INSTALLATION

3.1 BASE FOUNDATION AND SECURING POINTS

The machine must be leveled and firmly stationed on the floor where it is to be used, according to the Installation Diagram attached.

The floor load, must be suitable for the weight of the machine.

Before securing the machine a solid concrete base must be prepared to the specification of the machine.

The sizes for the bolt holes position are listed as A-B listed in the chart below. Check the sizes with the distributor

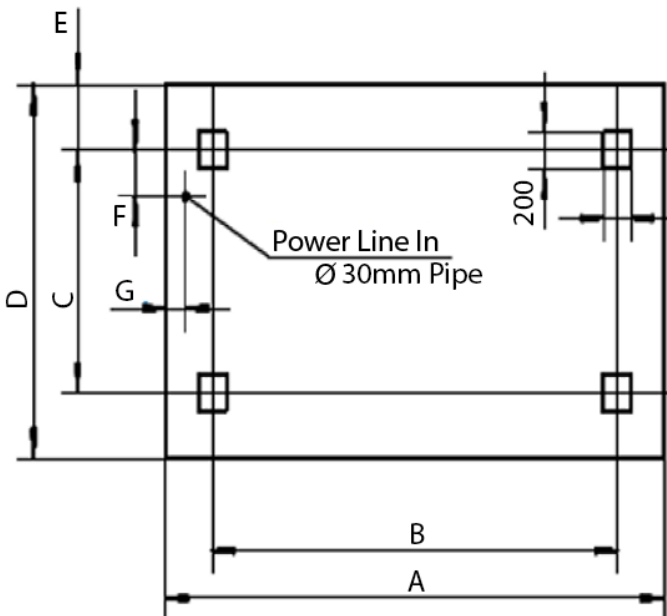
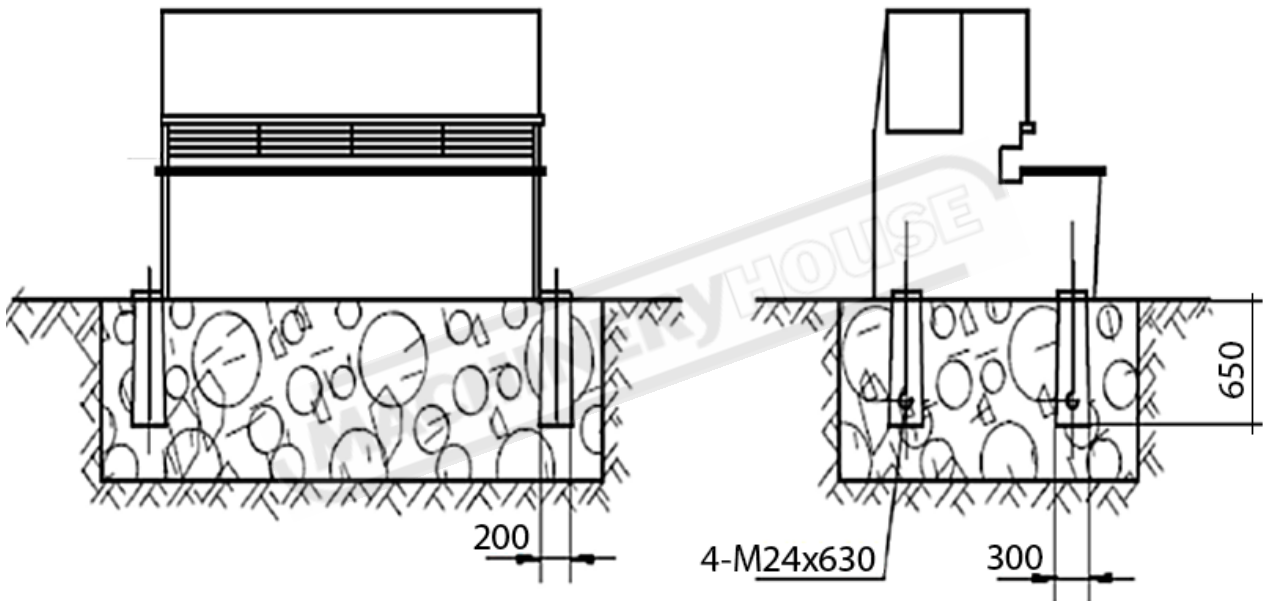

Table of Measurement

Model	A	B	C	D	E	F	G
HG-2504	3500	2840	1000	1750	300	130	100
HG-2506	3500	2880	1150	1900	300	130	100
HG-3206	4200	3583	1350	1900	300	130	100
HG-3212	4700	3655	1450	2350	430	180	350
HG-4005	5000	4382	1500	1900	300	130	100
HG-4012	5500	4445	1550	2550	480	160	350



OPERATION MANUAL

3.2 MACHINE LEVELING

To set your machine up so that it operates to optimum performance, apply the following procedure After your guillotine has been anchored to a concrete slab floor, it then needs to be leveled. The leveling is performed using the screws on each pad.(Fig. 3.1). Loosen the hold down bolts and place a level on the surface of the working table. Tolerances: 1000:0.30mm, for both longitudinal and transverse.

Metal plates need to be placed under each jacking screw to distribute the load. Once level then tighten the hold down bolts.

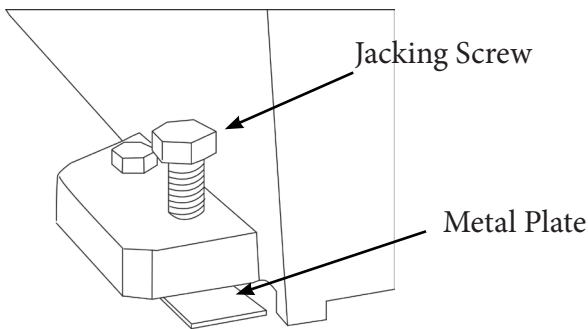

The machine must not rest on supports other than those defined in Fig. 3.1

Fig. 3.1

3.3 CHECKING THE POWER SUPPLY

METALMASTER machines are supplied wired ready to run. Check the specification plate on the machine to confirm that the voltage is compatible with the local power supply.

The machine must be connected to the power by a qualified and licensed electrician. Warranty may be voided if it is found that the connection was not carried out by a qualified electrician.

Check the rotation of the motor. If the direction does not match the diagram below, isolate the machine and change the wiring

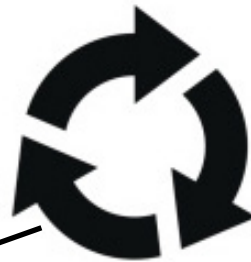

3.4 ATTACHING THE ACCESSORIES.

- Bolt the support arms onto the feed table. Ensure they are level and square to the table. (Fig 3.2)

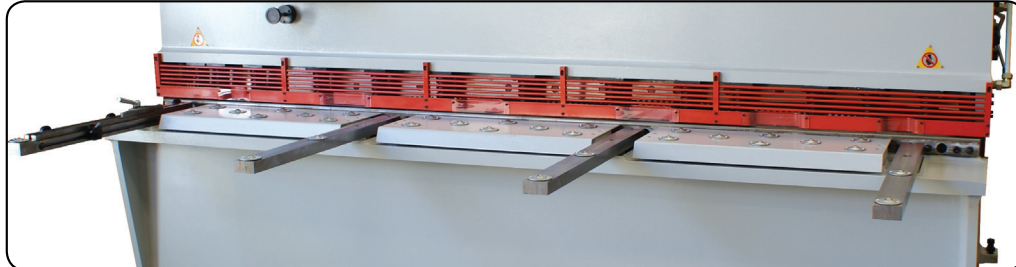

Fig. 3.2

- Place the squaring stops Fig 3.3 into position on the table top, securing into place with the bolts supplied. Check that the square stops are square to the blade. Adjust by loosening the bolts and moving by the amount allowed by the clearance of the holes.
- Re tighten the screws.



Fig. 3.3

- Unpack and attach the rear fence to the back of the machine. Ensure that the sensors have been connected and set up. (Fig.3.4)
- Unpack the mobile foot control and plug the into the socket provided on the machine. (Fig.3.5)

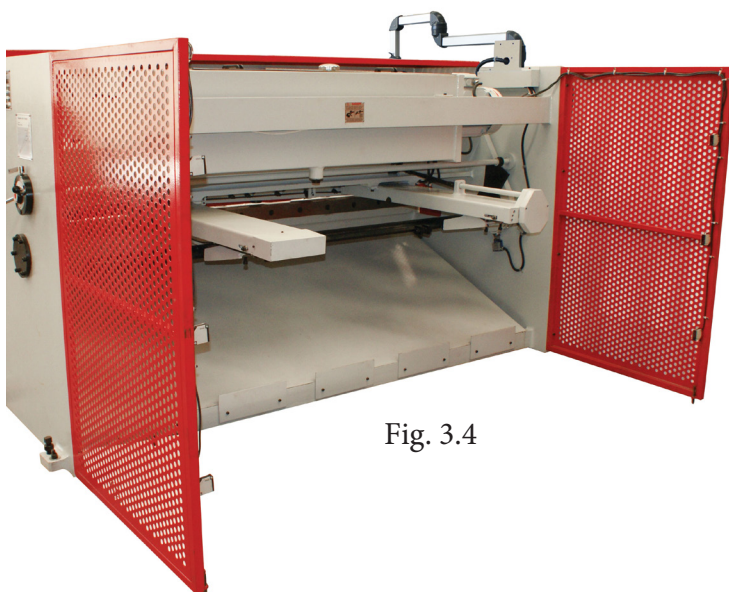

Fig. 3.4



Fig. 3.5

3.5 FILL THE HYDRAULIC OIL TANK.

When filling the tank with oil, make sure that the top of the tank is clean and free from dust and dirt.

- Remove the oil tank cover (Fig 5.5)
- Using a pump add the oil into the tank
- Oil level must be filled until the oil reaches the top mark of the oil indicator.
- Always keep the oil at the same level.



Fig. 5.5

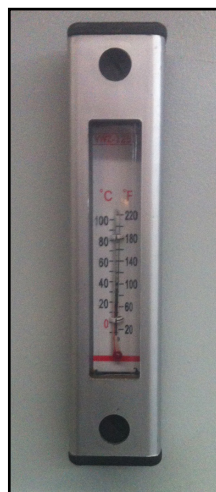

Sight Glass



Filler Cap



OPERATION MANUAL

4. COMMISSIONING

4.1. PREPARATION OF THE MACHINE.

- Remove all wrapping and packing grease from the machine.
- Check the machine for loose bolts. Tighten as required.
- Inspect for oil leakage or loose fittings. Similarly check the main rams between the top frames.
- Clean the blades and tighten the securing bolts as required. Examine the cutting edges of both blades for damage.
- Inform your service provider of any damage or faults with the machine.

4.2 OMROM E3Z SAFETY SENSOR ALIGNMENT

Warning- Follow all setup instructions before starting hydraulic pump.

The safety circuit consists of a reset switch and two rear side guards, each having 3 sensors. Your machine may or may not have a RED warning light. If there is no red warning light, then see the NC89 for display (Reset Rear Guard). When the main power is switched on or the rear sensors have been tripped the safety circuit must be reset before the hydraulic pump can be started.

Warning Indication: The safety circuit has not been Reset.

Red Warning Light



NC89 Display



or

Reset Switch

Press to reset safety circuit and then press OK on NC89.

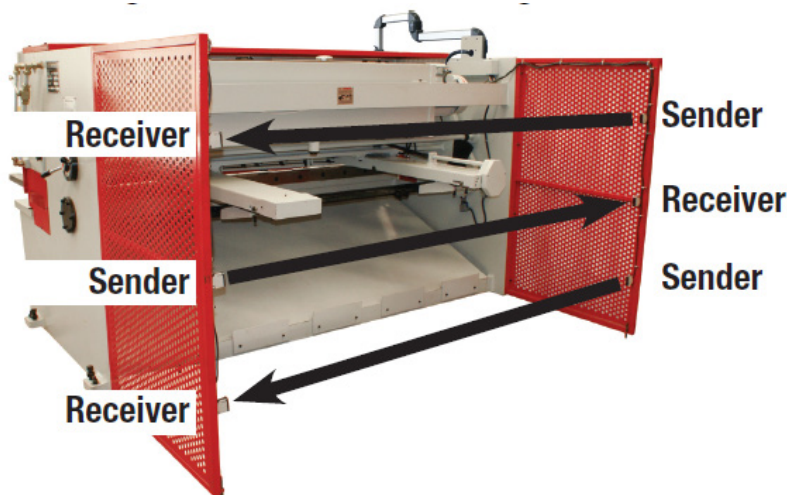
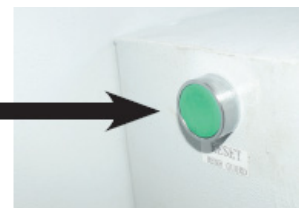



OPERATION MANUAL

4.2 OMROM E3Z SAFETY SENSOR ALIGNMENT. CONT.

Identifying Sensors

Sender

The sender has one red light on top of the unit and one red light at the front. These two lights will be on all the time while the machine has power.



Receiver

The receiver has two lights on top of the unit. The receiver should have one green light on or a red and green light on when all the sensors have been aligned correctly.



Receiver - No lights on. Indicates no power supply.



Receiver - Green light on. Indicates power is on but not aligned.



Receiver - Red & Green lights on. Indicates power is on & aligned.

Note: No.1 receiver could be mounted top, middle or bottom on the guard.

The receivers are wired in series so No.1 receiver will have a green light on, indicating it has power. When it is correctly aligned with its sender the red & green light will be on and it will send power to No.2 receiver.

No.2 receiver will have a green light on and when that receiver has been correctly aligned with its sender the red & green light will be on and it will send power to the No.3 receiver.

No.3 receiver is aligned using the same technique.

So when all 3 receivers are aligned correctly with their corresponding senders they should all have red and green lights on top of each unit.

Identifying Sensors



OPERATION MANUAL

4.2 OMROM E3Z SAFETY SENSOR ALIGNMENT. CONT.

Alignment of Senders & Receivers

Ensure that the machine is level and all four leveling jacking bolts are correctly adjusted. Check the rear guards are bolted tight and adjust the stabilizing feet to ground level to support the guards. The sensors are sensitive to alignment so try to align as accurately as possible. If the sender is only just aligned with the receiver, any vibration when cutting will stop the pump and the safety circuit will have to be reset again.

Loosen the sender screws and angle sender up until receiver loses alignment.

Angle sender down until receiver re-aligns and then loses alignment again.

Half way between these two positions is the most accurate alignment.

The sensors may also have to be angled sideways as well to get the best possible alignment. This may involve packing individual brackets or sensors.

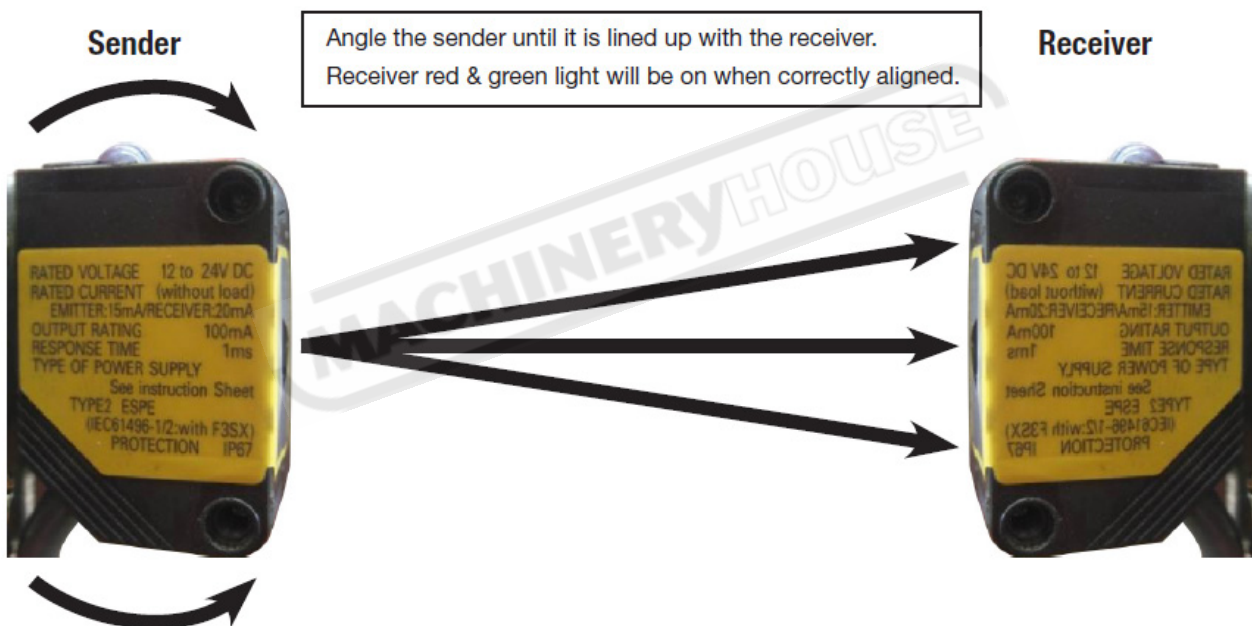

You can now reset the safety circuit & press OK on the NC89.

After a successful reset the NC89 screen should be the same as Fig. 1

The Pump can now be started



Fig. 1



OPERATION MANUAL

4.3 CALIBRATE "X" AXIS ON CONTROLLER

Before operating the machine the "X" axis needs to be checked. The following is that process.

- 1 Cut a piece of material and measure it with a vernier. Check the dimension against the x position on the readout. If the measurement is the same then the "X" axis has been set. If they are different then do the following.
- 2 With power off depress the red button on the controller and turn on the power key.
- 3 Arrow down to test and press ok
- 4 Arrow down to set position and press ok. The controller will ask you to enter the access code below..

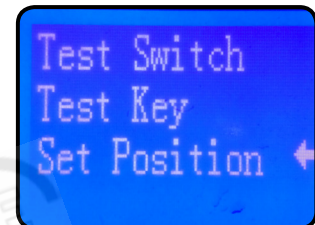
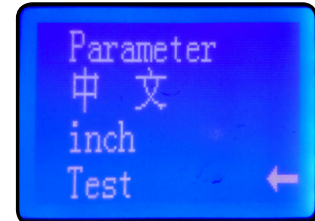
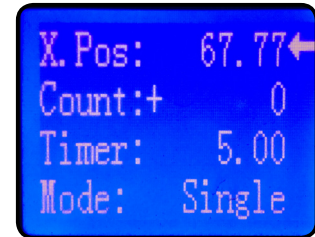

ACCESS CODE IS 258

- 5 After entering the access code delete size on screen and enter new size
- 6 Press ok to save changes
- 7 Press ESC 3 times to exit out to normal screen.

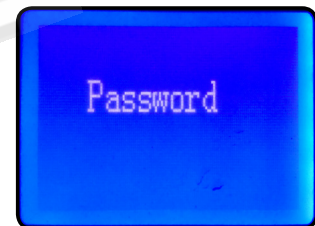
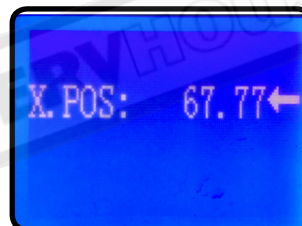

4.4. COMMISSIONING CHECK LIST.

Before starting the machine the following checks must be carried out.

- Installation and machine preparation has been performed according to the manuals instructions.
- Fill the oil reservoir with 46 grade hydraulic oil and ensure that the oil filter breather cap is fitted
- All grease nipple points have been lubricated.
- Electrical earth fitted and power circuits, switches, and foot-pedal checked.
- Check power connections and any damage to any wiring.
- Setup rear sensors
- Check pump rotation.
- Test safety operation, Estop, rear sensors, stop button etc.
- Test controller operation.
- Test all mechanical operation on the machine including blade and back gauge travel and limit switch operation.
- Calibrate x axis on controller.
- Test cut material and check quality of cut
- Tools, equipment and personnel are clear of the machine.
- Operation Manual on how to operate the machine has been read.



OPERATION MANUAL

5. OPERATION INSTRUCTIONS

5.1 PRE-OPERATIONAL SAFETY CHECK PRIOR TO OPERATING

Before operating the machine the rear safety beam guard needs to be checked. Below are the steps that need to be followed.

1. Start machine as per instruction procedures
2. Stand outside rear safety gate & obstruct sensor (1)
3. Ensure machine has stopped and is disabled
4. Check your control: Warning light (A) Warning message (B)
5. Press green reset button rear of electrical box image (D)
6. Press OK on NC-89 control panel to activate guard system (B)
7. Repeat steps 1 to 6 for each sensor (2) & (3)

A: Basic Control - Light on



B: NC-89 Control Display



C: Rear Guarding Sensors



D: Guard Reset Button



Emergency Stop Check,

1. Start machine as per instruction procedures
2. Press emergency stop button on control panel
3. Ensure machine has stopped and is disabled
4. Reset emergency stop button by twisting red dial (Some models need guard to also be reset) (D)
5. Repeat steps 1 to 4 for each emergency stop on your machine

E: Rear Guarding Sensors



D: Guard Reset Button



5.2 NC89 CONTROLLER OPERATION

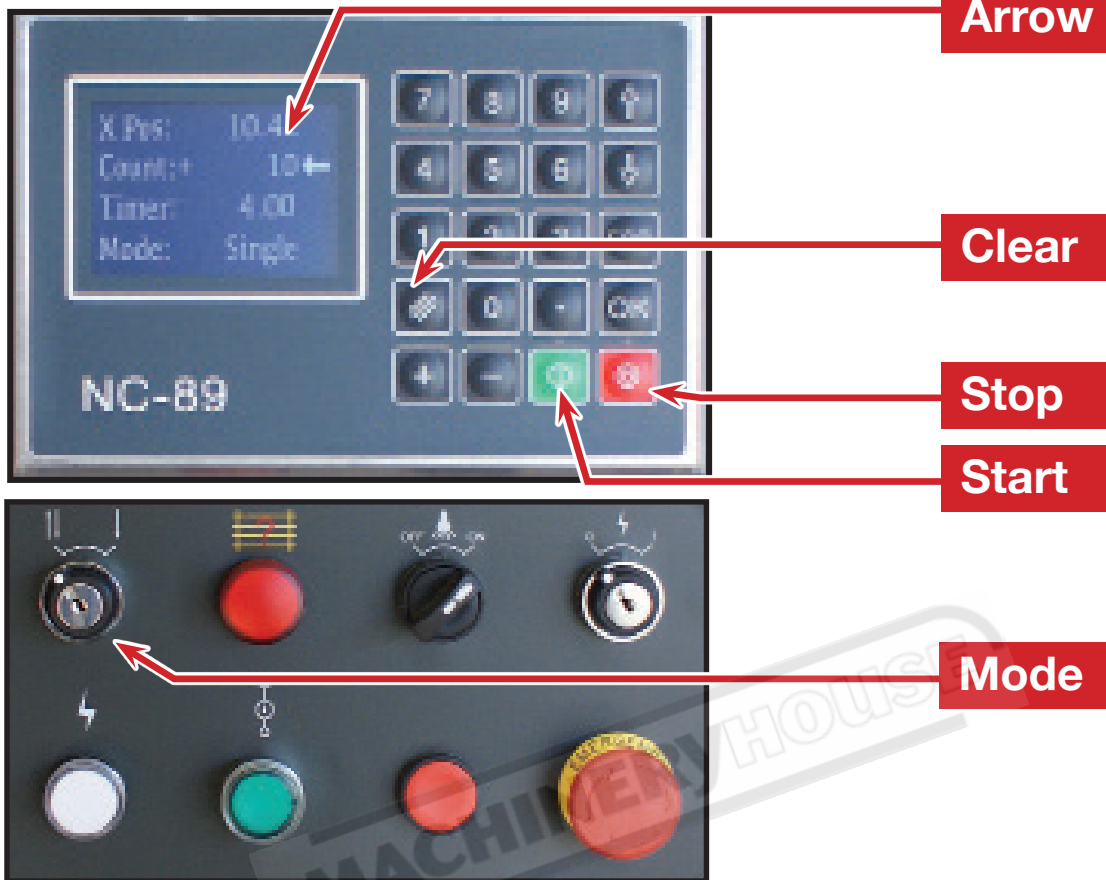





X. Pos: Back gauge position.



Operation: Move Arrow to X Pos, clear number , enter desired value, press  and  start button.

The back gauge will now go to the new entered position to within 0.5mm. Once back gauge has stopped searching use the manual handle for fine adjustment.

Count: Number of cuts.

Count can be cleared at any time by using clear  button, It will then count upwards with each cut. A set number can also be entered. **Operation:** Move Arrow to Count, clear the number,  enter eg. 3 and press  After 3 cuts it will count down to 0 and the controller will stop cutting. You must now arrow down to Count and then press  for counting upwards or enter any number for counting downwards.

Timer: Length of cut.

The length of cut can be changed to suit the width of material being cut. **Operation:** Arrow down to timer, clear value and enter new value for cut length time, press  and  start button.

Mode: Cont / Single

Mode Single - Used to perform 1 cut at a time when foot pedal is pressed.

Mode Cont - Used to perform continuous cutting when foot pedal is pressed.



OPERATION MANUAL

5.3 SETTING THE BLADE GAP

To adjust the blade gap for the material thickness and type, firstly check Fig 5.3 for correct setting.

Adjustment Table of Gap

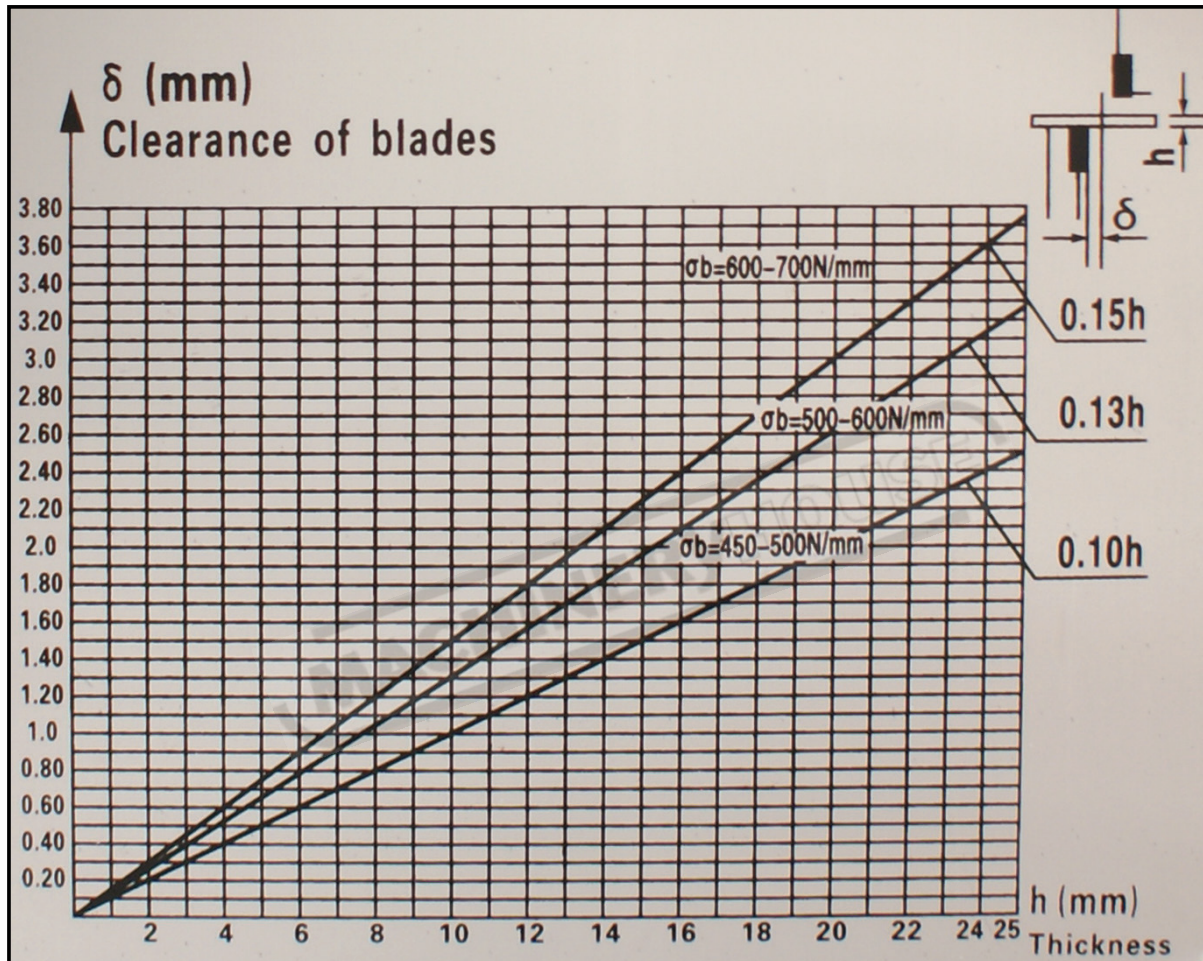
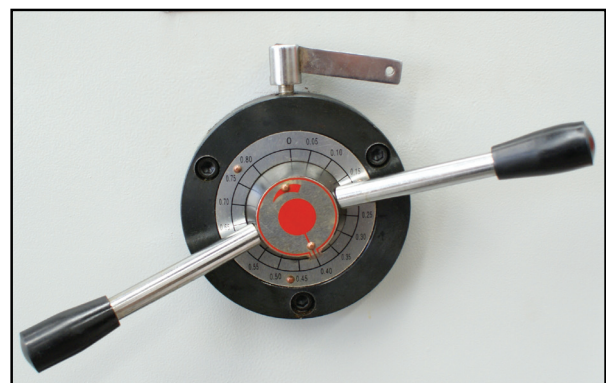

Fig. 5.3

Then adjust the hand wheel (Fig 5.4) to correct graduated setting.

Fig. 5.4





OPERATION MANUAL

6. MAINTENANCE AND INSPECTION

6.1 TYPE AND FREQUENCY OF INSPECTIONS

Inspection	Period	Responsibility
Lubrication of all grease points	Daily	Operator
Lubrication of slide-ways	Weekly	Operator
All Guards that protect against physical damage	Daily	Operator
Machine fixing bolts against loosening	Weekly	Operator
Oil leakage in cylinders	Weekly	Operator
Hydraulic Oil Change and filter	1000hrs	Maintenance
Oil leakage in pipes, hoses and hydraulic elements	Weekly	Operator
Hydraulic fluid level	Weekly	Operator
Cylinder connections bolts against loosening	Weekly	Operator
Safety & limit switches against loosening, damage	Weekly	Operator
Terminal connections of the electrical installation	Annually	Electrician

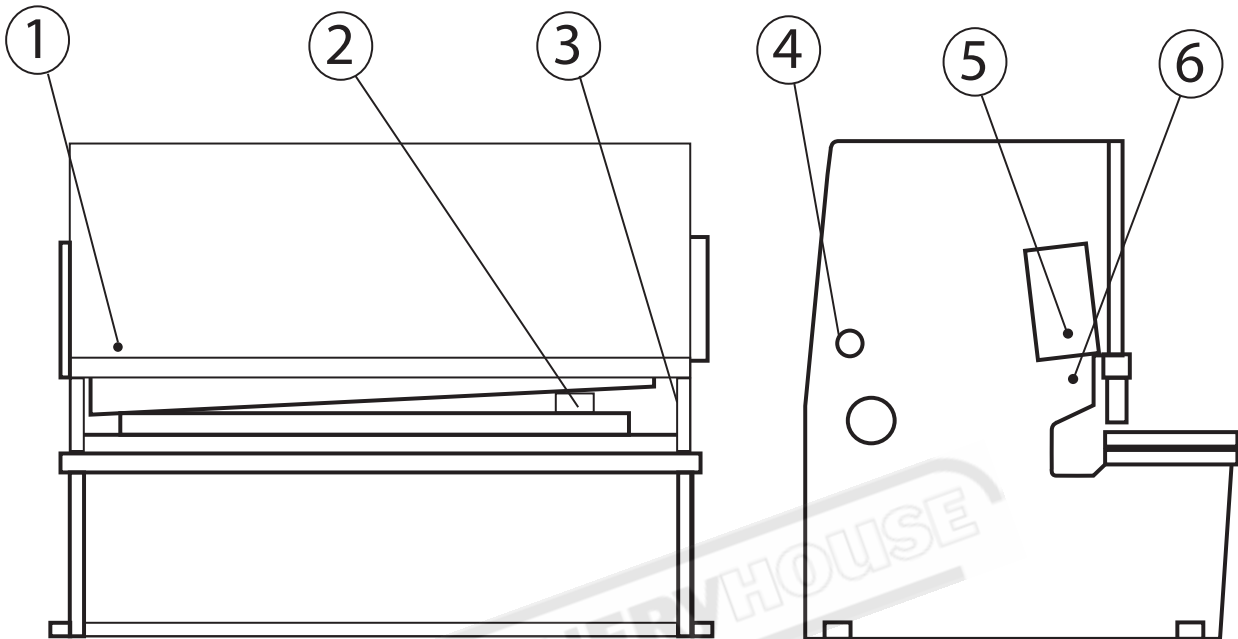
METALMASTER**OPERATION MANUAL****6.2 LUBRICATION POINTS****Lubricants.**

- Cylinder and main pivot points - grease.
- Back-stop: shafts, screws, nuts - grease.
- Shear beam slides - grease.
- Hydraulic oil #46.

6.3 CHANGING THE HYDRAULIC OIL

All precautions must be taken to keep the hydraulic system clean at all times
When changing oil, make sure that the top of the oil tank is clean and free from dust and dirt.

- Remove the oil tank cover (Fig 6.5)
- Using an appropriate pump, drain out the old oil completely. Be sure nothing is left
- Using a pump, add the new oil into the tank.
- Oil level must be filled until the oil reaches the top mark of the oil indicator.
- Always keep the oil at the same level.
- Oil must be changed after the first 200 working hours of use, and then after every 1000 working hours (See: Lubrication Diagram Fig. 6.4).

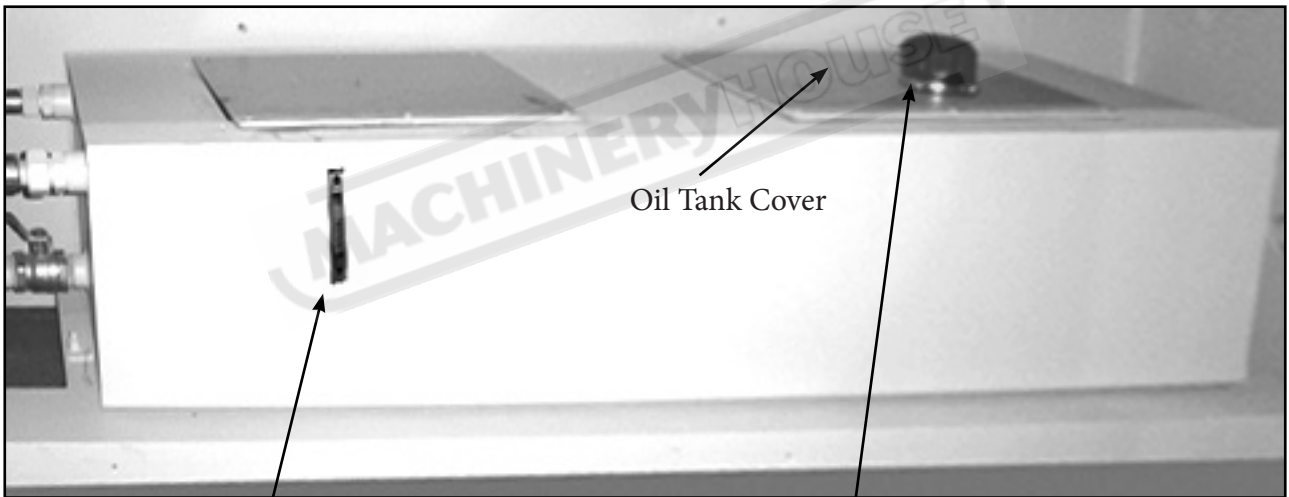
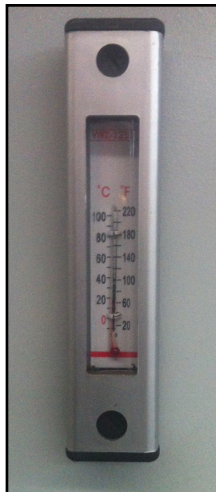

Fig. 6.5



Sight Glass



Filler Cap

6.4 CHANGING THE FILTER

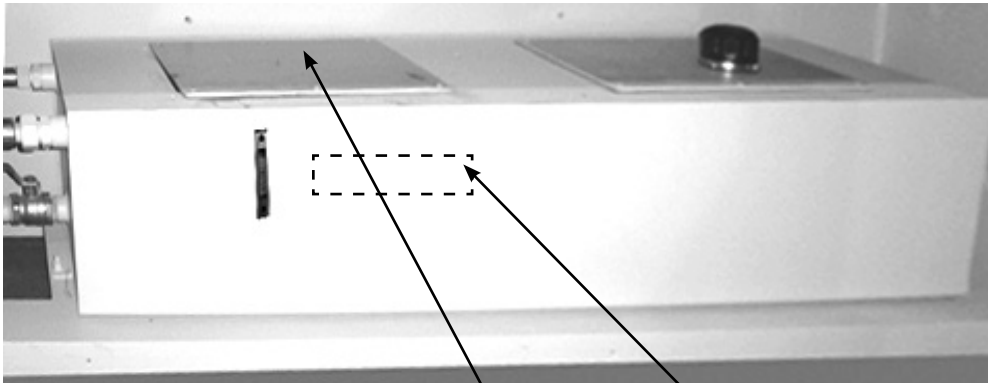
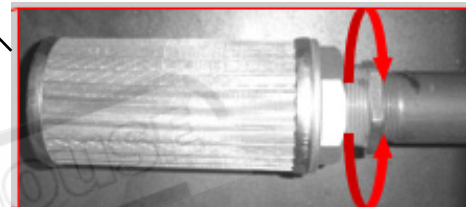

Fig. 6.6

Cover



- Remove the cover on the oil tank. (Fig.6.6)
- Unscrew the old filter from its place inside the oil tank
- Screw the new filter into its place in the tank and replace the cover

Note ! The suction filter element must be cleaned after the first 200 hours of use, and then after every 1000 working hours. Replace if damaged or unserviceable.

6.5. BLADE PARALLEL ADJUSTMENT.

The following information also applies when fitting new or sharpened blades.

This is a two man job where one will need to check the blade clearance with a feeler gauge (Fig 6.5) from the rear of the machine while the other adjusts the blade holder setting.

- The clearance is checked across the full length of the blades.
- Use feeler gauges, to test the clearance.
- According to the test adjust the clearance.

TO CHECK THE CLEARANCE AT SET INTERVALS ON THE BLADE.

- Set the selector control on the control box to normal operation function.
- Depress the foot pedal and move the blade to the maximum down stroke position then shut off the ball valve in Fig 6.6 to hold the down stroke position.
- Release the ball valve slowly to allow the upward movement of the blades to check the clearance at set intersection intervals of the blades.
- Once the clearances are equal and parallel tighten all fasteners and locknut's and release the ball valve fully.
- This operation may be required to be repeated until clearances are correct and equal.

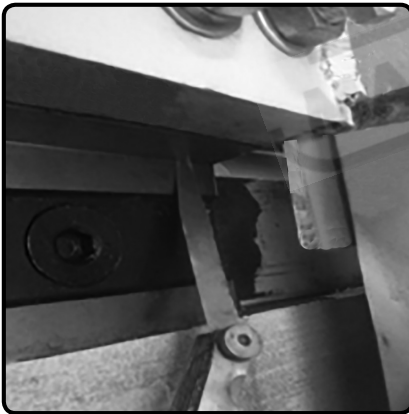

Fig. 6.5

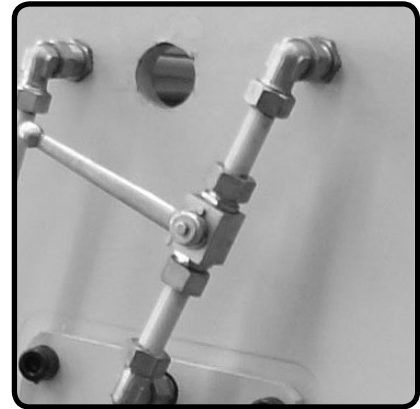

Fig. 6.6

On completion of the blade setting, re-check the electrical system and then press the foot pedal and allow the machine to continually cycle for two minutes. Test the cutting at maximum rated capacity. Check the hydraulic system for oil leaks. Replace and secure all covers on completion of commissioning



OPERATION MANUAL

6.6 TROUBLESHOOTING

PROBLEM	POSSIBLE CAUSES	ACTION
Machine shudder on the down stroke.	<ul style="list-style-type: none"> • Incorrect relief valve setting 	<ul style="list-style-type: none"> • Re-adjust relief valve Adjust the relief valve by unlocking the hexagon head grub screw on the side of the body of the valve. Turn in a clockwise direction closing the valve while cycling the machine.
Machine will not cut.	<ul style="list-style-type: none"> • Low system oil pressure • Check the blades for excessive clearance or damage to the cutting edges 	<ol style="list-style-type: none"> 1. Check the system pressure. (See page 4) 2. Check the oil level (See page 24). 3. Check the blade gap (See page 21). 4. Check the blade clearance (See page 26) 5. Reset or regrind the blades as required
Machine will not stop in the neutral position.	<ul style="list-style-type: none"> • Check limit switch /relay • Check directional control valve 	<ul style="list-style-type: none"> • Replace if necessary. • Remove valve, check and replace if necessary
Clamping does not work	<ul style="list-style-type: none"> • No clamping pressure 	<ol style="list-style-type: none"> 1. Check the system pressure. (See page 4) 2. Check electrical circuit
Oil leaking from cylinder	<ul style="list-style-type: none"> • Gland seal is damaged 	<ul style="list-style-type: none"> • Change seal
Oil leaking from fittings	<ul style="list-style-type: none"> • Fittings are loose 	<ul style="list-style-type: none"> • Tighten fittings



OPERATION MANUAL

A. HYDRAULIC CIRCUIT FOR HG-2504, HG-2506, HG-3206, HG-4006

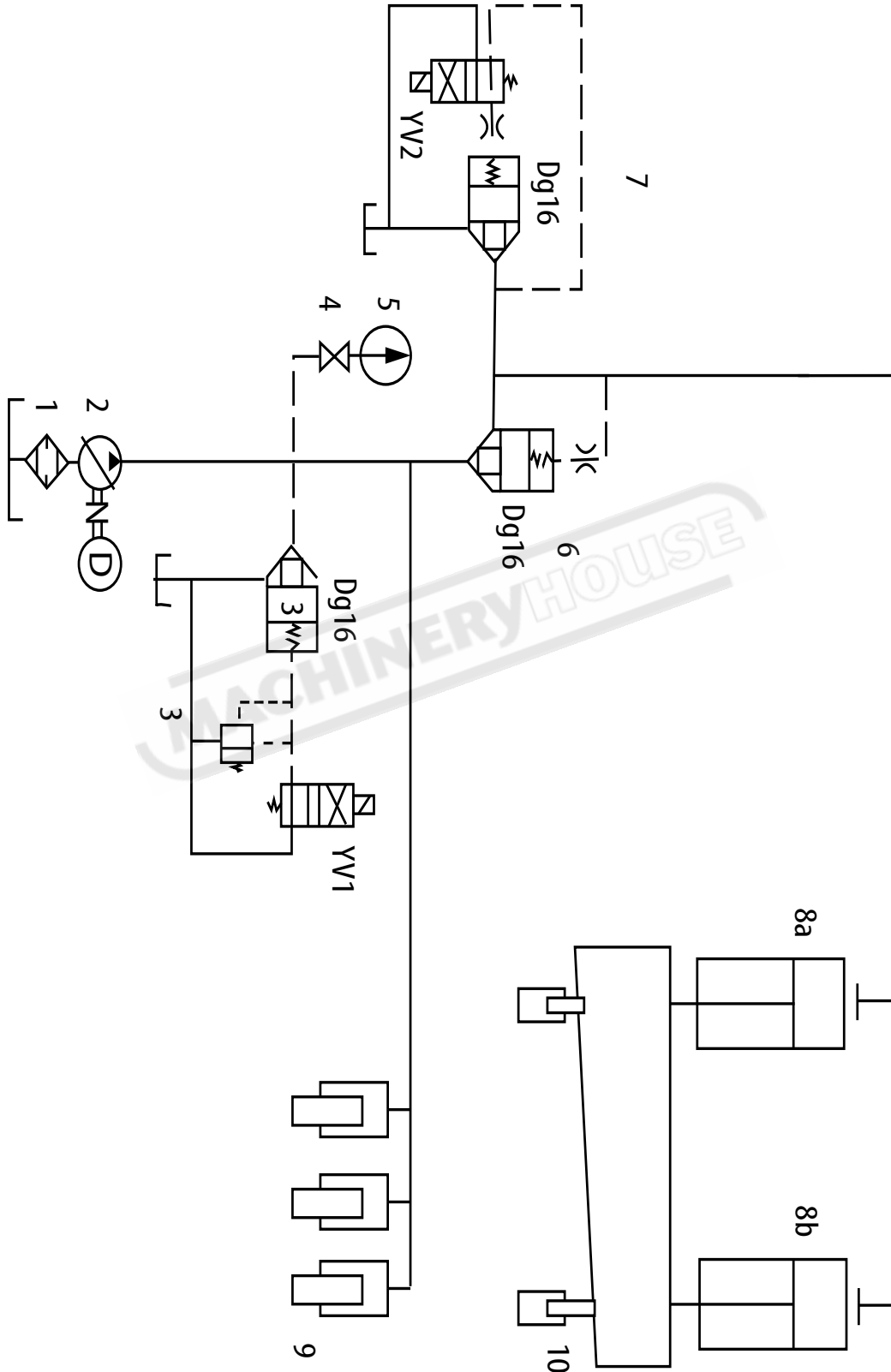



OPERATION MANUAL

A. HYDRAULIC CIRCUIT FOR HG-3212, HG-4012

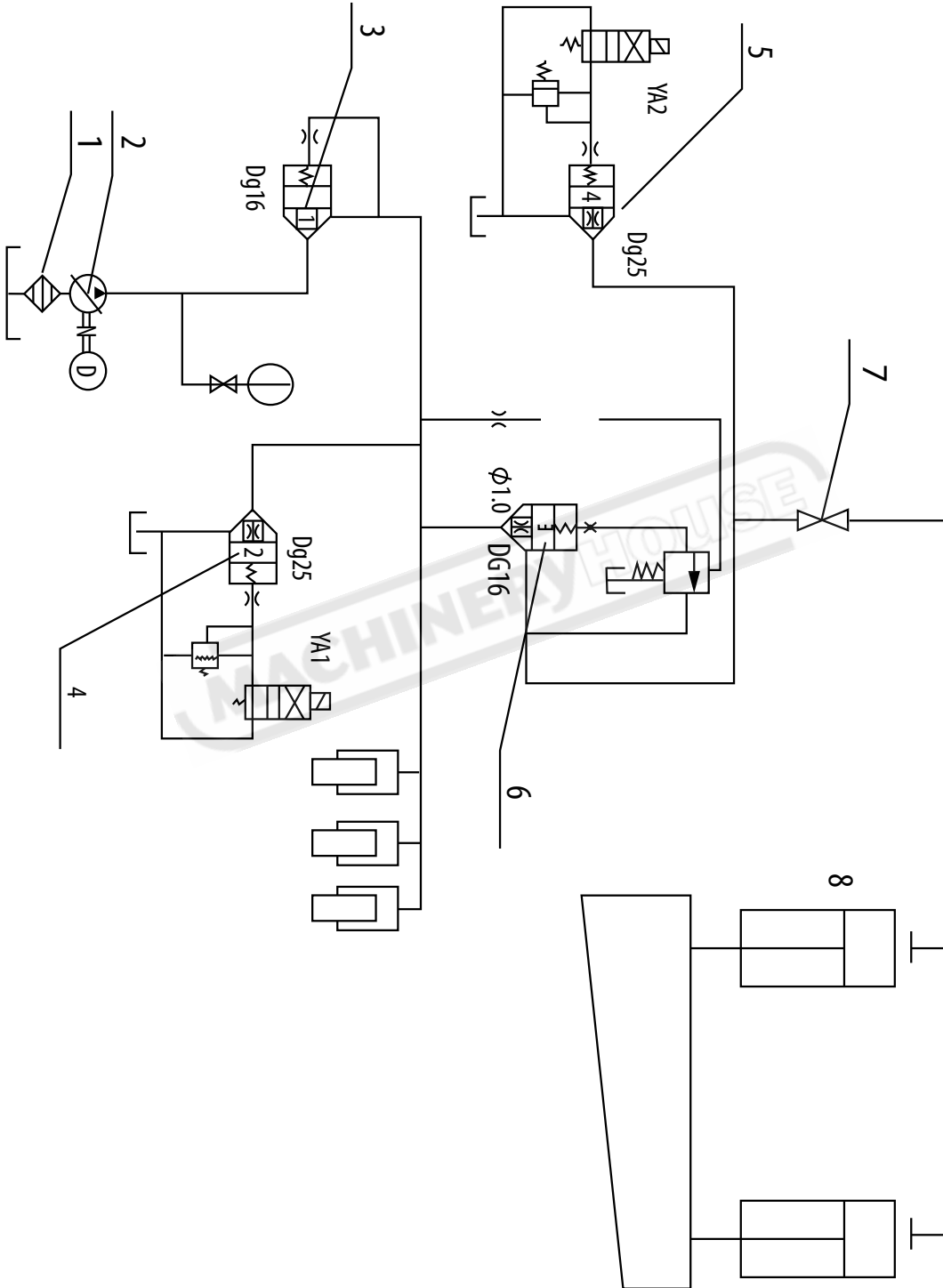



OPERATION MANUAL

B. ELECTRIC CIRCUIT DIAGRAM HG-2504, HG-2506, HG-3206, HG-4006

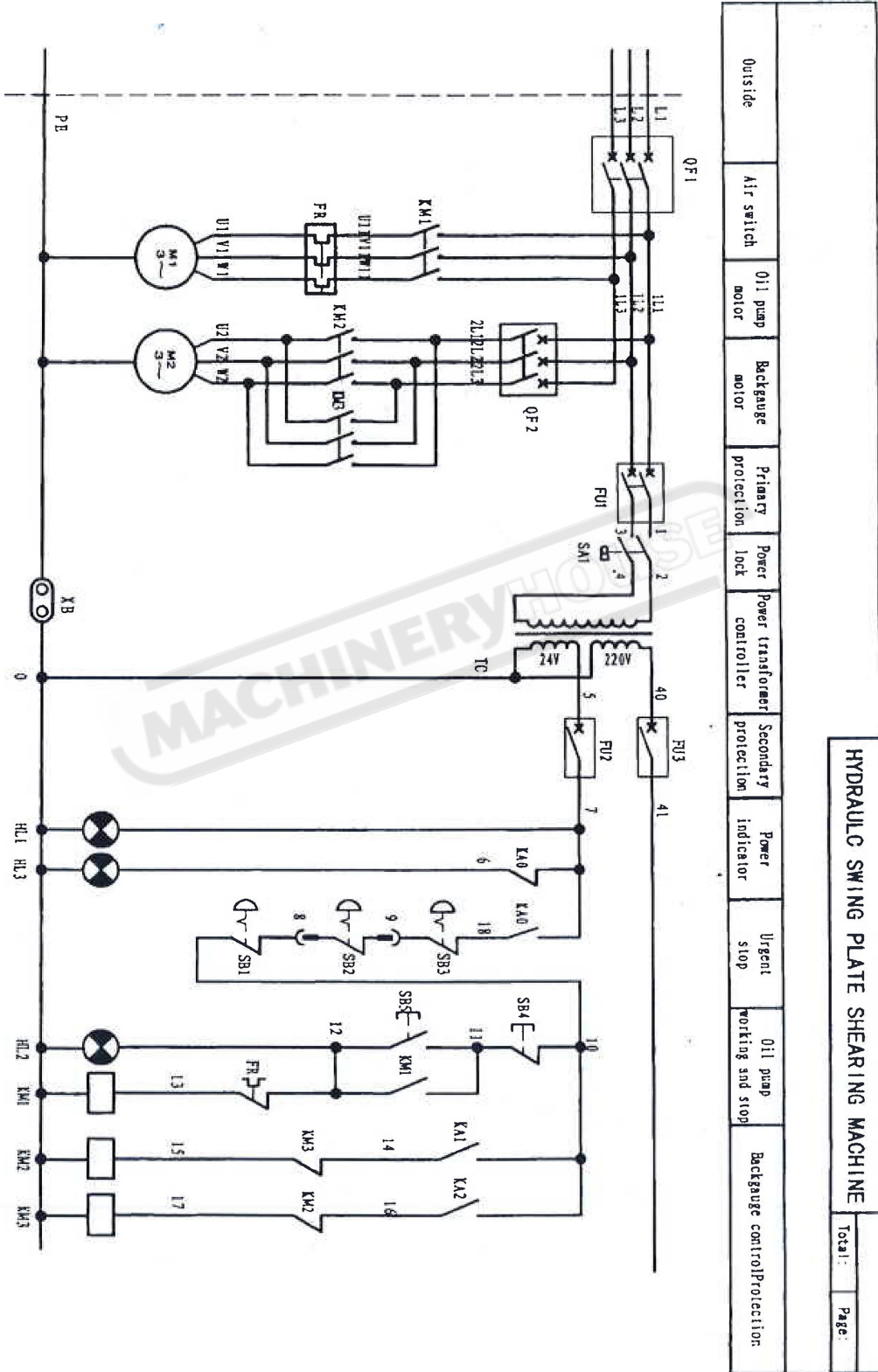

HYDRAULIC SWING PLATE SHEARING MACHINE											
Outside	Air switch	Oil pump motor	Backgauge motor	Primary protection	Power lock	Power transformer controller	Secondary protection	Power indicator	Urgent stop	Oil pump working and stop	Backgauge control/Protection
Total: _____ Page: _____											



OPERATION MANUAL

B. NC89 ELECTRIC CIRCUIT DIAGRAM HG-2504, HG-2506, HG-3206, HG-4006

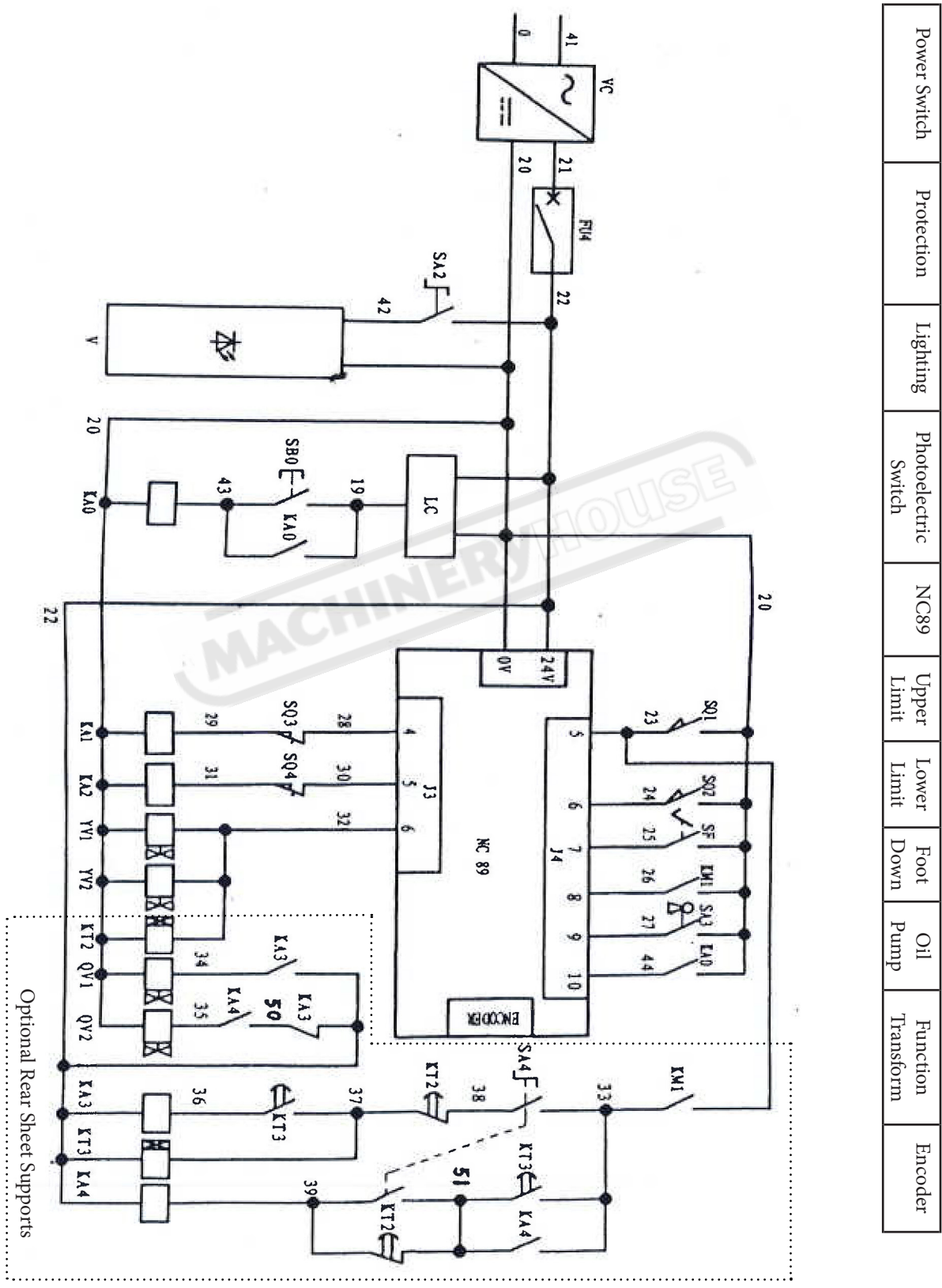

Power Switch	Protection	Lighting	Photoelectric Switch	NC89	Upper Limit	Lower Limit	Foot Down	Oil Pump	Function Transform	Encoder
--------------	------------	----------	----------------------	------	-------------	-------------	-----------	----------	--------------------	---------



OPERATION MANUAL

B. ELECTRIC CIRCUIT DIAGRAM HG-3212, HG-4012

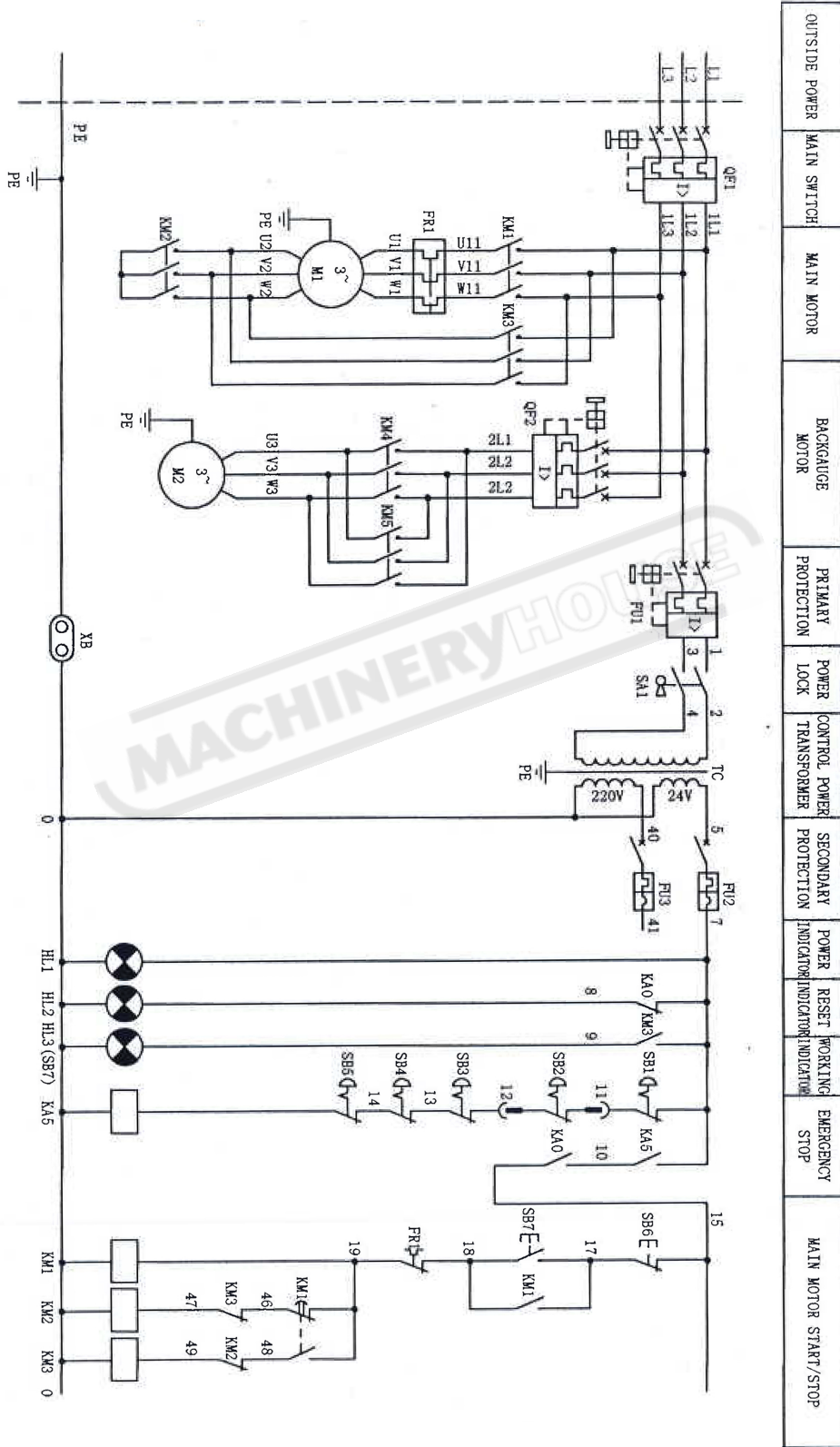

OUTSIDE POWER	MAIN SWITCH	MAIN MOTOR	BACKGAUGE MOTOR	PRIMARY PROTECTION	POWER LOCK	CONTROL POWER TRANSFORMER	SECONDARY PROTECTION	POWER INDICATOR	RESET INDICATOR	WORKING INDICATOR	EMERGENCY STOP	MAIN MOTOR START/STOP
---------------	-------------	------------	-----------------	--------------------	------------	---------------------------	----------------------	-----------------	-----------------	-------------------	----------------	-----------------------



OPERATION MANUAL

B NC89 ELECTRIC CIRCUIT DIAGRAM HG-3212, HG-4012

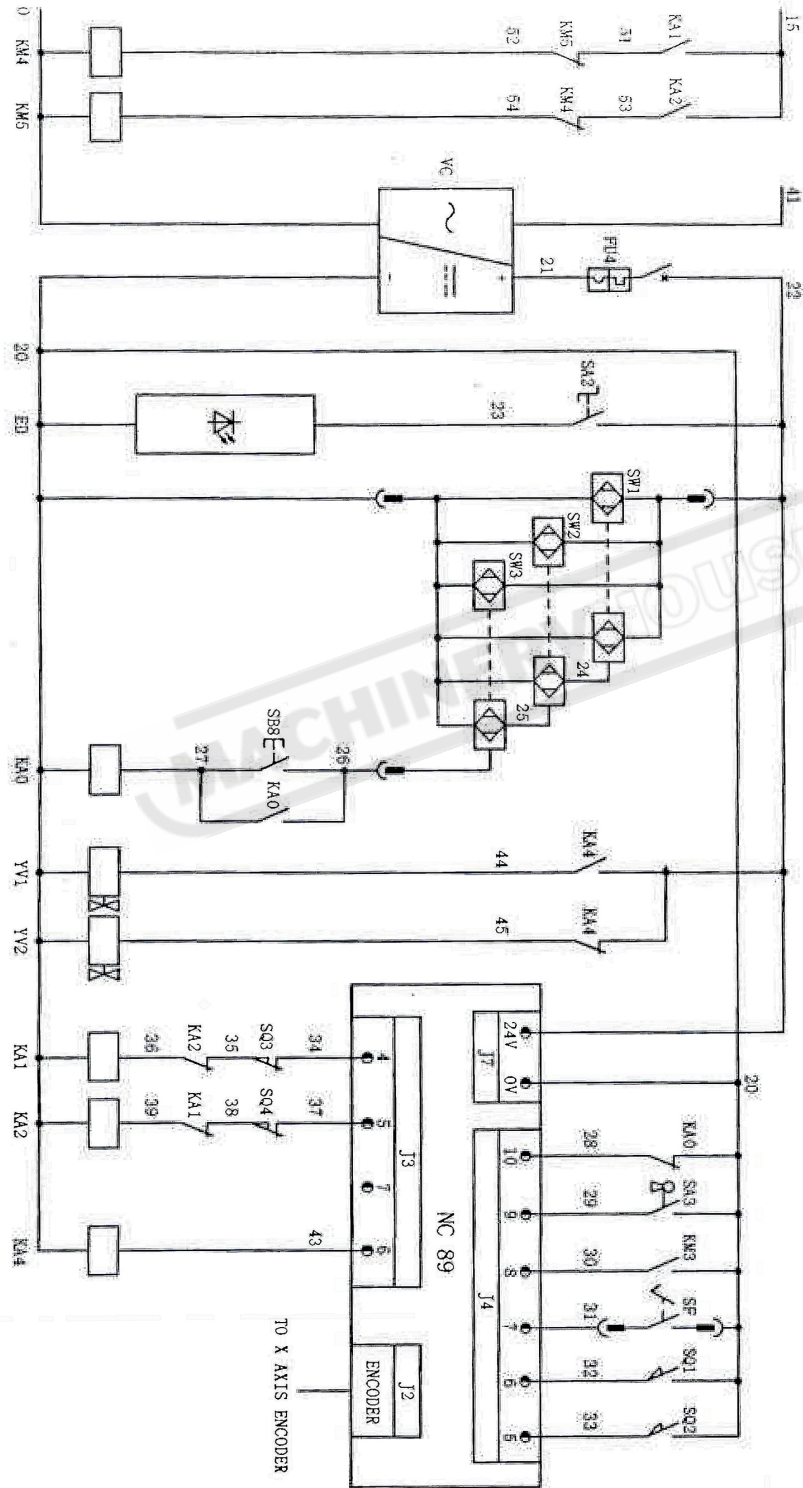

BACKGROUND CONTROL	DC POWER	LIGHTING	PHOTOELECTRIC SWITCH	RESET	MAGNETIC VALVES	NC89	RESET INPUT	FUNCTION TRANSFORMER	PUMP START	PEDAL DOWN	LOWER LIMIT	UPWARD LIMIT
--------------------	----------	----------	----------------------	-------	-----------------	------	-------------	----------------------	------------	------------	-------------	--------------



WARNING

General Machinery Safety Instructions

Machinery House
requires you to read this entire Manual before using this machine.

- 1. Read the entire Manual before starting machinery.** Machinery may cause serious injury if not correctly used.
- 2. Always use correct hearing protection when operating machinery.** Machinery noise may cause permanent hearing damage.
- 3. Machinery must never be used when tired, or under the influence of drugs or alcohol.** When running machinery you must be alert at all times.
- 4. Wear correct Clothing.** At all times remove all loose clothing, necklaces, rings, jewelry, etc. Long hair must be contained in a hair net. Non-slip protective footwear must be worn.
- 5. Always wear correct respirators around fumes or dust when operating machinery.** Machinery fumes & dust can cause serious respiratory illness. Dust extractors must be used where applicable.
- 6. Always wear correct safety glasses.** When machining you must use the correct eye protection to prevent injuring your eyes.
- 7. Keep work clean and make sure you have good lighting.** Cluttered and dark shadows may cause accidents.
- 8. Personnel must be properly trained or well supervised when operating machinery.** Make sure you have clear and safe understanding of the machine you are operating.
- 9. Keep children and visitors away.** Make sure children and visitors are at a safe distance for you work area.
- 10. Keep your workshop childproof.** Use padlocks, Turn off master power switches and remove start switch keys.
- 11. Never leave machine unattended.** Turn power off and wait till machine has come to a complete stop before leaving the machine unattended.
- 12. Make a safe working environment.** Do not use machine in a damp, wet area, or where flammable or noxious fumes may exist.
- 13. Disconnect main power before service machine.** Make sure power switch is in the off position before re-connecting.
- 14. Use correct amperage extension cords.** Undersized extension cords overheat and lose power. Replace extension cords if they become damaged.
- 15. Keep machine well maintained.** Keep blades sharp and clean for best and safest performance. Follow instructions when lubricating and changing accessories.
- 16. Keep machine well guarded.** Make sure guards on machine are in place and are all working correctly.
- 17. Do not overreach.** Keep proper footing and balance at all times.
- 18. Secure workpiece.** Use clamps or a vice to hold the workpiece where practical. Keeping the workpiece secure will free up your hand to operate the machine and will protect hand from injury.
- 19. Check machine over before operating.** Check machine for damaged parts, loose bolts, Keys and wrenches left on machine and any other conditions that may effect the machines operation. Repair and replace damaged parts.
- 20. Use recommended accessories.** Refer to instruction manual or ask correct service officer when using accessories. The use of improper accessories may cause the risk of injury.
- 21. Do not force machinery.** Work at the speed and capacity at which the machine or accessory was designed.
- 22. Use correct lifting practice.** Always use the correct lifting methods when using machinery. Incorrect lifting methods can cause serious injury.
- 23. Lock mobile bases.** Make sure any mobile bases are locked before using machine.
- 24. Allergic reactions.** Certain metal shavings and cutting fluids may cause an allergic reaction in people and animals, especially when cutting as the fumes can be inhaled. Make sure you know what type of metal and cutting fluid you will be exposed to and how to avoid contamination.
- 25. Call for help.** If at any time you experience difficulties, stop the machine and call you nearest branch service department for help.

WARNING

Power Operated Guillotine Safety Instructions

Machinery House
requires you to read this entire Manual before using this machine.

- 1. Maintenance.** Make sure the Guillotine is turned off and disconnect from the main power supply and make sure all moving parts have come to a complete stop before any inspection, adjustment or maintenance is carried out.
- 2. Guillotine Condition.** Guillotine must be maintained for a proper working condition. Never operate a Guillotine that has low oil levels, damaged or worn parts. Scheduled routine maintenance should be performed on a scheduled basis.
- 3. Blade Condition.** Never operate a Guillotine with a damaged or badly worn blades. Replace if required.
- 4. Pump Direction.** Pump rotation must be in arrow direction otherwise the pump will be damaged.
- 5. Hand Hazard.** Keep hands and fingers clear from moving parts. Serious injury can occur if hand or finger tips come between blades.
- 6. Personal Protection.** Gloves are recommended when handling the workpieces.
- 7. Authorized and trained personnel.** The machine must be operated by authorized and trained personnel. The shear is designed to be operated by a single user. Using the machine with more than one operator is forbidden, except for certain maintenance situations.
- 8. Power outage.** In the event of a power failure during use of the machine, turn off all switches to avoid possible sudden start up once power is restored.
- 9. Work area hazards.** Keep the area around the Guillotine clean from oil, tools, objects & chips. Pay attention to other persons in the area and know what is going on around the area to ensure unintended accidents.
- 10. Guards.** Operate machine only with all protective devices and guarding in place and operational. Never remove, defeat or bypass. Any presence-sensing safeguarding used must have regular Safety integrity tests and records kept. These records must be kept for 5 years or for the life of the plant and be handed to any person that you relinquish control of the plant to. Tests include stop time measurements, safety distance calculations and inspections, with operator checks and periodic maintenance checks. (WHS Regulation 226)
- 11. Material.** Material must NOT be hardened ceramic or glass-originated, non flat metals (at origin) e.g. rods, bars, tubes & pipes.
- 12. Blade gap adjustment.** Do NOT operate the machine without proper blade gap adjustment according to sheet thickness.
- 13. Warning Labels.** Take note of any warning labels on the machine and do not remove them.
- 14. Backgauge Area.** Do not access the backgauge area, while the machine is working.
- 15. Protective fence.** Do not bridge the safety limit switch of the rear protective fence.
- 16. Squaring arm.** Do not use side squaring arm and front support arms for intermediate storage of workpieces.
- 17. Operation.** During the shearing process, the workpiece may slide or move unexpectedly. Therefore, the material must be handled carefully.
- 18. Emergency stop.** Use the emergency stop button in case of any emergency.
- 19. Level machine.** Level the machine on a flat concrete surface by using a spirit level.
- 20. Overloading machine.** Do not exceed the rated capacity of the guillotine. Please refer to the manual for capacities.
- 21. Hearing protection and hazards.** Always wear hearing protection as noise generated from machine and workpiece can cause permanent hearing loss over time.
- 22. Call for help.** If at any time you experience difficulties, stop the machine and call your nearest branch service department for help.

PLANT SAFETY PROGRAM NEW MACHINERY HAZARD IDENTIFICATION, ASSESSMENT & CONTROL

Power Operated Guillotine

Developed in Co-operation Between A.W.I.S.A and Australia Chamber of Manufactures
This program is based upon the Safe Work Australia, Code of Practice - Managing Risks of Plant in the Workplace (WHSA 2011 No10)

Item No.	Hazard Identification	Hazard Assessment	Risk Control Strategies <small>(Recommended for Purchase / Buyer / User)</small>
B	CRUSHING	LOW	Secure & support work material on table.
C	CUTTING, STABBING, PUNCTURING	MEDIUM	Wear gloves to prevent cuts from sharp material offcuts.
D	SHEARING	MEDIUM	Hands should be kept clear of moving parts and blades. Isolate power to machine prior to any checks or maintenance. Ensure front blade guard is fitted securely. Do not adjust or clean until machine has fully stopped. Access to the rear of machine must be interlock or photoelectric guarded to prevent access when the machine is operating, (see workover authority principles of machine guarding for guidelines).
F	STRIKING	MEDIUM	Wear safety glasses. Stand clear of falling offcuts. Ensure material hold downs are correctly adjusted. Ensure guards are secured properly.
H	ELECTRICAL	MEDIUM	Machine should be installed & checked by a Licensed Electrician. All electrical enclosures should only be opened with a tool that is not to be kept with the machine.
O	OTHER HAZARDS, NOISE.	LOW	Wear hearing protection as required.
Plant Safety Program to be read in conjunction with manufactures instructions			



www.machineryhouse.com.au



www.machineryhouse.co.nz

Authorised and signed by:
Safety officer:
Manager: 

Revised Date: 25th Sept 2015